

Lockheed Martin  
Your Mission Is Ours.™



SIKORSKY  
**M28**® | MULTI-MISSION  
UTILITY AIRCRAFT  
The Ultimate in Short Takeoff & Landing Versatility

6900 Main Street  
Stratford, Connecticut 06615 USA  
+1 (800) WINGED-S (946-4337)  
International +1 (203) 386-3029  
[www.lockheedmartin.com/sikorsky](http://www.lockheedmartin.com/sikorsky)





# M28<sup>®</sup> MULTI-MISSION UTILITY AIRPLANE

Indispensable for Mission Success



Backed by a world leader in highly-versatile flight solutions, the M28 multi-purpose utility airplane (designed and produced at PZL Mielec, A Lockheed Martin Company) is trusted worldwide in some of the most hostile environments and extreme altitudes. With short takeoff and landing capabilities, and payload performance among the best in its class, the M28 aircraft represents the best value solution for a wide range of military and commercial applications.

...WE DELIVER





NO MATTER YOUR...

CLIMATE



ENVIRONMENT/  
INFRASTRUCTURE



MISSION



**PZLM**elec  
A Lockheed Martin Company

LEARN MORE ABOUT THE M28® AT  
[www.m28aircraft.com](http://www.m28aircraft.com)



# M28<sup>®</sup> SAFETY LIKE NO OTHER

Offering the Most Safety Features as Standard



Our ATO helps with all  
the required paperwork -  
for FAA - EASA





# M28<sup>®</sup> SUPPORT PROGRAM

Rapid Operational Turnaround

## SUPPORT CAPABILITIES

- Modern Maintenance Facilities
- Specialized Maintenance Hangar
- Qualified and Certified Personnel
- FSRs and Mobile Teams



## TRAINING

### PILOT TRAINING:

- Theoretical (Class) 72h
- Practical (in flight) 8h

### PILOT INSTRUCTOR TRAINING:

- Theoretical (Class) 10h
- Practical (in flight) 10h



## MAINTENANCE

### PERIODICAL:

- Every 200 FH or 400 LC or Every 12 Months
- Every 600 FH or 1200 LC or Every 24 Months
- Every 1200 FH or 2400 LC or Every 48 Months

### PROGRESSIVE:

- Scope Approved by Local CAA
- OJT on Request

### NON-SCHEDULED:

- Current Discrepancies
- Troubleshooting Problem Removal



## SAFETY EQUIPMENT

- Low maintenance bleed air based Ice Protection System certified Flight Into Known Icing (FIKI)
- FDR Flight Data Recorder
- FA2100 Voice Recorder
- EGPWS Mk VI System
- TCAS II (mod. 7.1) CAS100B with TA/RA Indicators
- ADS-B Transponder (EHS/ELS)
- RDR2000 Weather Radar
- Standard dual GPS system with precision approaches

## PERFORMANCE

- Class leading STOL performance (Take-off distance 1800 ft - 548 m; landing distance 1640 ft - 499 m)
- Exceptional low stall speed handling due to unique wing design (automatic slots and spoilers)
- Best in-class OEI (One Engine Inoperative) climbing performance (640 fpm at MTOW)

## AIRFRAME

- Durable airframe designed for rough (-50°C, 50°C) conditions PT6A-65B P&WC engines with high TBO, protected by inlet particle separators
- Ruggedized and durable fixed landing gear with low pressure tires for unprepared runways





# M28<sup>®</sup> HIGH TEMPERATURE RANGE. HIGH PAYLOAD. HIGH ENDURANCE.

To Reach Distant and Remote Locations that are Often Unpaved.

## M28<sup>®</sup> SPECIFICATIONS

### PERFORMANCE

Standard Day, Sea Level, maximum takeoff gross weight

Maximum Gross Weight	16,534 lb	7,500 kg
Empty Weight	9,601 lb	4,354 kg
Payload	5,070 lb	2,300 kg
Maximum Fuel Load	3,894 lb/602 US Gal	1,766 kg/2,278 l
Takeoff Power	2 x 1,100 shp	2 x 820 kW
Average Fuel Consumption (10,000 ft)	591 lb/h	268 kg/h
Max Operating Speed	192 kts	355 km/h
Minimum/Stall Speed (MTOW)	65 kts	120 km/h
Max Rate of Climb (MTOW)	2,420 ft/min	12.29 m/s
Takeoff Distance (unless otherwise noted)	1,800 ft	548 m
Landing Distance (unless otherwise noted)	1,640 ft	499 m
Service Ceiling	25,000 ft	7,620 m
Max Range (10,000 ft. 45 min. reserve)	860 nm	1,592 km
Endurance (10,000 ft. 45 min. reserve)	6.2 hrs	

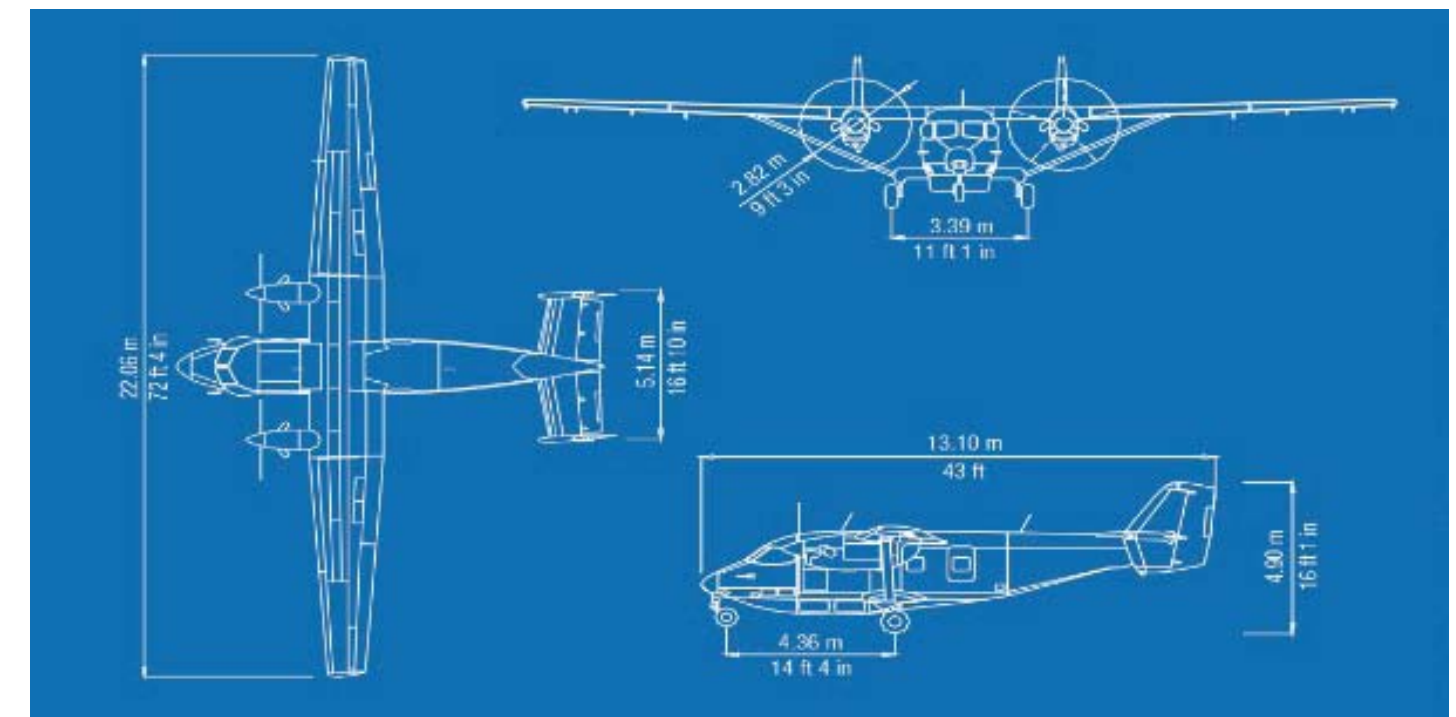

The M28 can operate from any type of runway – unpaved, grass and gravel – including the world’s most inaccessible airstrips and high-elevation airfields. Fueled at max gross weight for more than 6 hours’ endurance, and designed to perform across a wide temperature range (-50°C, 50°C), the M28 has what it takes to bring people and cargo into and out of difficult-to-reach locations.

PHOTO: 3rd Airlift Wing Base, Poland



JRANCE.





# M28<sup>®</sup> LAUNCH INTO ANY ENVIRONMENT

Equipped to Operate Safely Wherever Your Mission Takes You



FLIR Camera

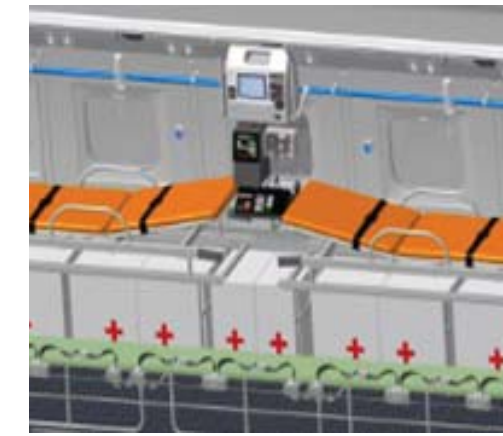

CASEVAC Life Saving Equipment



Cargo Hoist

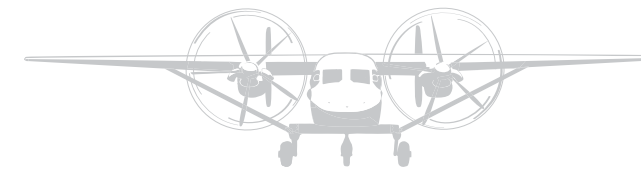

**OFFERING THE MOST SAFETY  
FEATURES AS STANDARD**

- TCAS II
- Flight Data Recorder
- Cockpit Voice Recorder
- Emergency Locator Beacon
- Flight Data Recorder
- EGPWS<sup>®</sup>
- Weather Radar



# M28<sup>®</sup> FULLY DEVELOPED MISSION OPTIONS

Customize Your Configuration with No Development Risk

## MISSION EQUIPMENT



360 Degree Surveillance Radar



Cargo Roller Floor



Special Parachuting Equipment



Entrance Rear Clamshell Door

## SAFETY



Analog Cockpit



Glass Cockpit

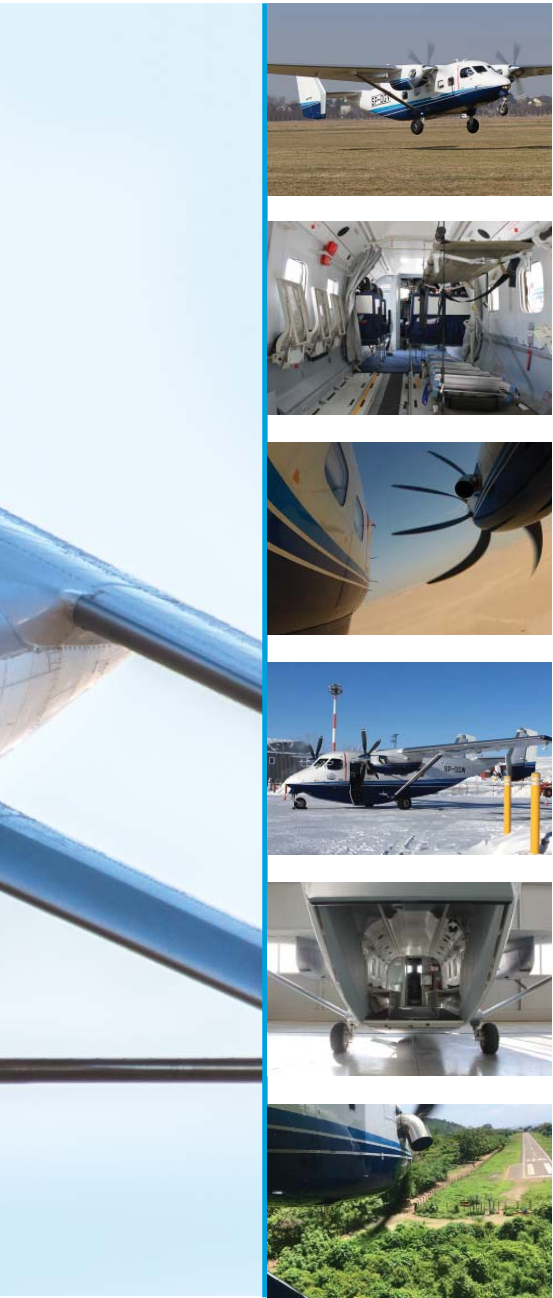

Excellent STOL Capability  
Unpaved, Grass & Gravel Runways

Fast & Easy Reconfiguration

Hot & High Performance  
VFR/IFR, Day/Night

Certified for Flying into Known Icing Conditions

Proven Air Drop System

Type Certificate  
USA (FAA), Indonesia (DGAC), European (EASA), Taiwan (CAA),  
Nepal (CAAN), Colombia (CAA), Brazil (ANAC), India (DGCA),  
Africa (SACAA),



# M28<sup>®</sup> UNMATCHED ADVANTAGES

Capability and Versatility that Enhance Mission Effectiveness





# M28<sup>®</sup> MULTI-MISSION UTILITY AIRPLANE

Best in Class. Trusted Worldwide.



## KEY ADVANTAGES



**PAX TO CARGO RECONFIGURATION TIME**  
7 Minutes



**STOL PERFORMANCE**  
Take-off Distance = 1800 ft / 548m  
Landing Distance = 1640 ft / 499m



**PAYLOAD**  
5,070 lb / 2,300 kg



**CABIN HEIGHT**  
5.63 ft / 1.72 m



**CABIN VOLUME**  
485 ft<sup>3</sup> / 13.73 m<sup>3</sup>



**PASSENGERS**  
19



**MAX OPERATING SPEED**  
192 kts / 355 km/h



**MAX RANGE**  
860 nm - 1,592 km



# M28<sup>®</sup> MULTI-MISSION UTILITY AIRPLANE

Shortest Takeoff. Widest Mission Range.



MARITIME PATROL



PARATROOP



COMBI



VIP



# M28<sup>®</sup> ONE AIRCRAFT, MANY MISSIONS.

Proven in Commercial and Military Roles

## MARITIME PATROL

- System: Mission Computer, Data Loader Recorder, Ethernet Switch, Video Encoder
- Sensors: 360° Radar, EO/IR, LRF, Direction Finder, AIS, SatCom, Data-Link
- Open system architecture, Consoles Roll-on, Day & Night, all weather, over land and maritime sensors
- 100% ITAR free

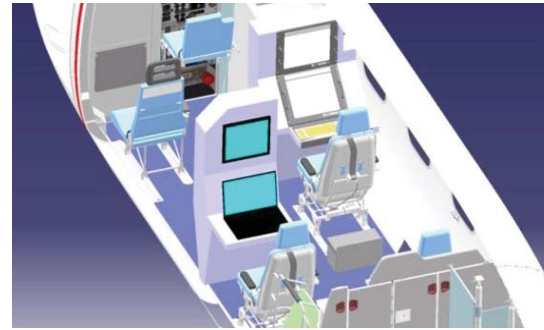

## PARATROOP

- Benches for 17 paratroopers
- Jump control gate, paratroop operation control panel (acoustic & lighting), hand-rails along the cabin walls, static lines
- Rear door hydraulically openable inside



## COMBI

- Forward-facing passenger seats
- Cargo tie-down area
- Cargo Hoist

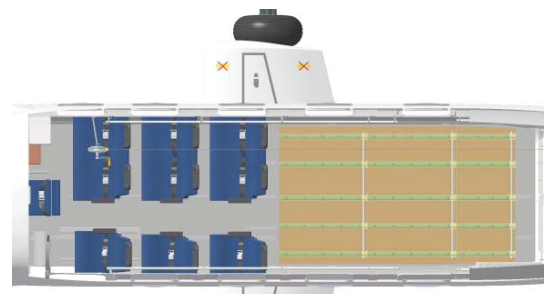

## VIP

- 8 Club Seats
- 1 Attendant Seat
- 1 Aft Galley
- Forward Lavatory
- Forward and Aft Bulkhead
- Air Conditioning System





# M28<sup>®</sup> ONE AIRCRAFT, MANY MISSIONS.

Designed for Rapid Role Change

## PASSENGER TRANSPORT

- 19 foldable passenger seats
- Seating for 18 passengers in a 6-row configuration
- 1 foldable passenger side seat



PASSENGER TRANSPORT

## MEDICAL EVACUATION

- 6 stretchers plus 9 seats
- Can be modified to flying ambulance configuration with life saving equipment



MEDICAL EVACUATION

## CARGO TRANSPORT

- 2000kg of maximum cargo load (additional 300kg of cargo in under-fuselage pod)
- Floor-mounted rollers
- Cargo Hoist



CARGO TRANSPORT

## SEARCH & RESCUE

- System: Mission Computer, Data Loader Recorder, Ethernet Switch, Video Encoder
- Sensors: 360° Radar, EO/IR, LRF, Direction Finder, AIS
- SatCom, Data-Link
- Equipment: COSPAS/SARSAT buoys, SAR rafts, light flares
- Open system architecture, Roll-on, Roll-off
- Day & Night, VFR/IFR, over land and maritime
- 100% ITAR free

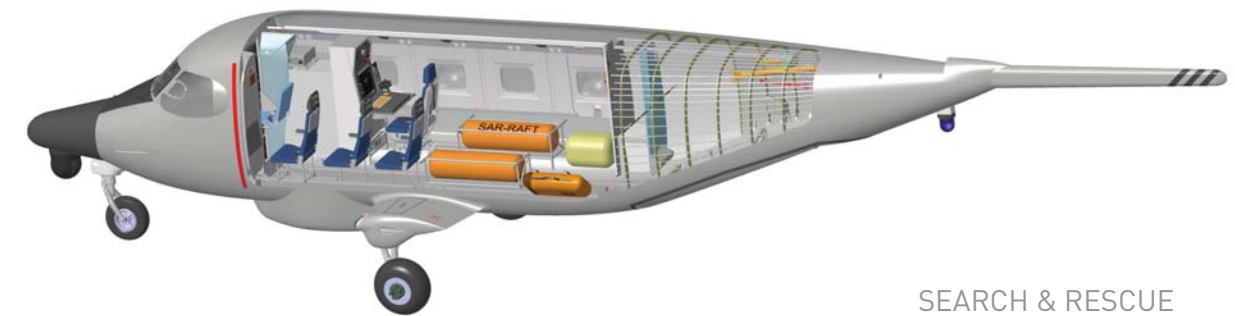

SEARCH & RESCUE